

# CROSS

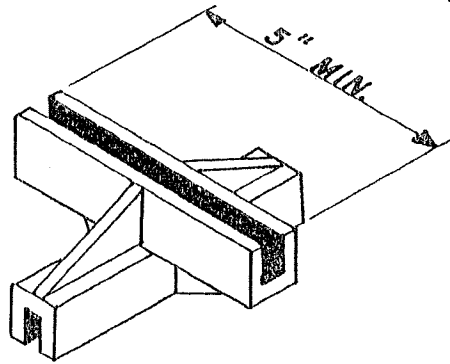

# CAP

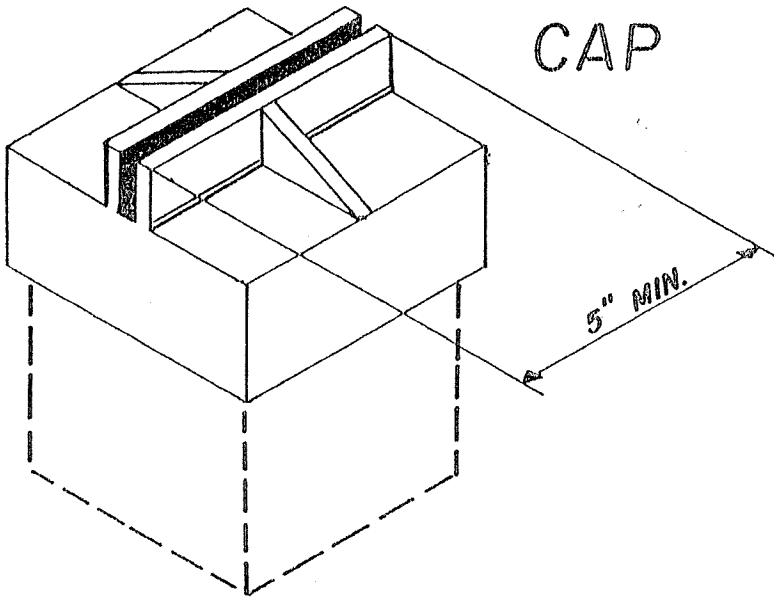

## GENERAL NOTES

1. Caps are placed on top of posts. Signs slide into blade.
2. Crosses are used at intersections where two street name signs are required on one post.

FAIRBANKS NORTH STAR BOROUGH  
809 PIONEER RD., FBKS AK 99701

TITLE/DWG. NO.

UPPER AND LOWER  
SIGN BRACKET

SS-101

DRAWN BY	DATE	APPROVED BY	DATE	REVISION
				0

GENERAL NOTES

- ① Recommended 6'-0" (min. distance 6'-0", max. distance 12'-0")
- ② Recommended 12'-0" (min. distance 6'-0", max. distance 50'-0")

NOTE: Minimum distance of sign from state-maintained road is 12'-0"

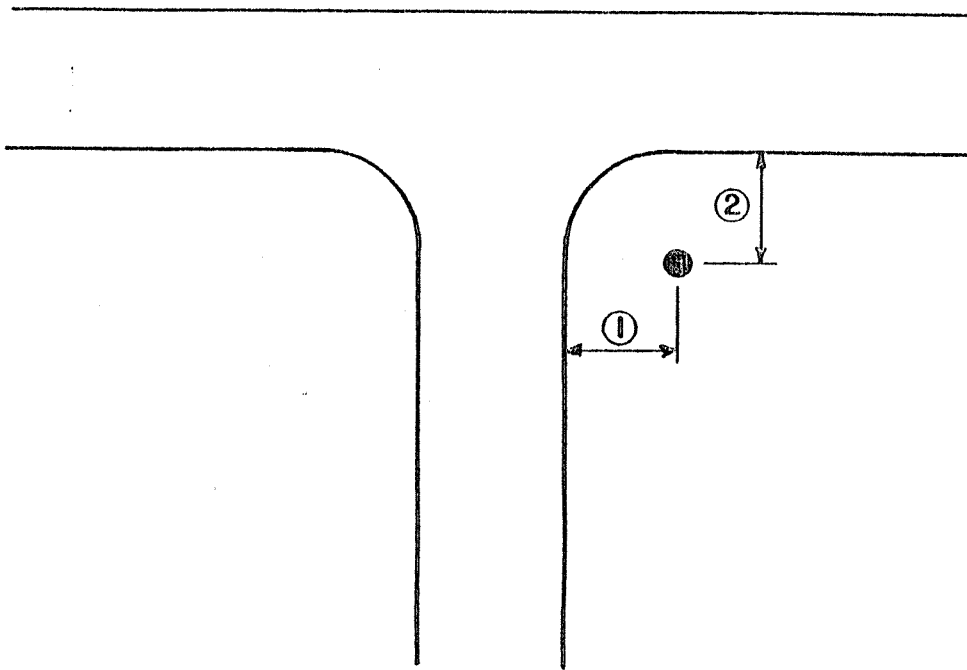

STREET SIGN LOCATION

FAIRBANKS NORTH STAR BOROUGH  
809 PIONEER RD., FBKS AK 99701

TITLE / DWG. NO.

STREET SIGN LOCATION  
DETAIL

SS-102

DRAWN BY	DATE	APPROVED BY	DATE	REVISION
				0

ITEM NO	QUAN (EA)	DESCRIPTION
1	1	Sleeve
2	1	Post
3	1	Anchor Bolt consists of 1ea 5/16" Bolt, A-307 2ea 5/16" Flat Washer, A-36 1ea 5/16" Nut, A-307

GENERAL NOTES

NOTE: Concrete embedment must be used on all state-maintained rights-of-way.

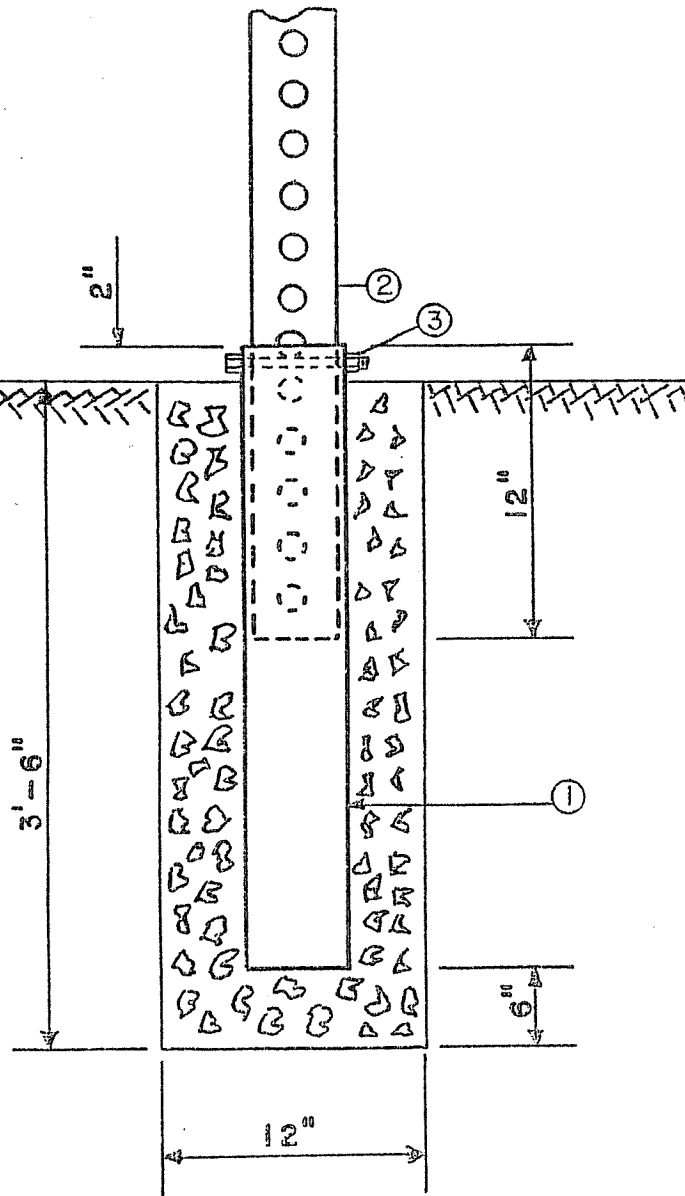

FAIRBANKS NORTH STAR BOROUGH  
809 PIONEER RD., FBKS AK 99701

TITLE/DWG. NO.

SLEEVE TYPE WITH  
CONCRETE FOUNDATION

SS-103

DRAWN BY	DATE	APPROVED BY	DATE	REVISION
				0

ITEM NO	QUAN (EA)	DESCRIPTION
1	1	Post
2	1	Sleeve
3	1	Anchor Bolt, consisting of 1ea 5/16" Bolt, A-307 2ea 5/16" Flat Washer, A-36 1ea 5/16" Nut, A-307

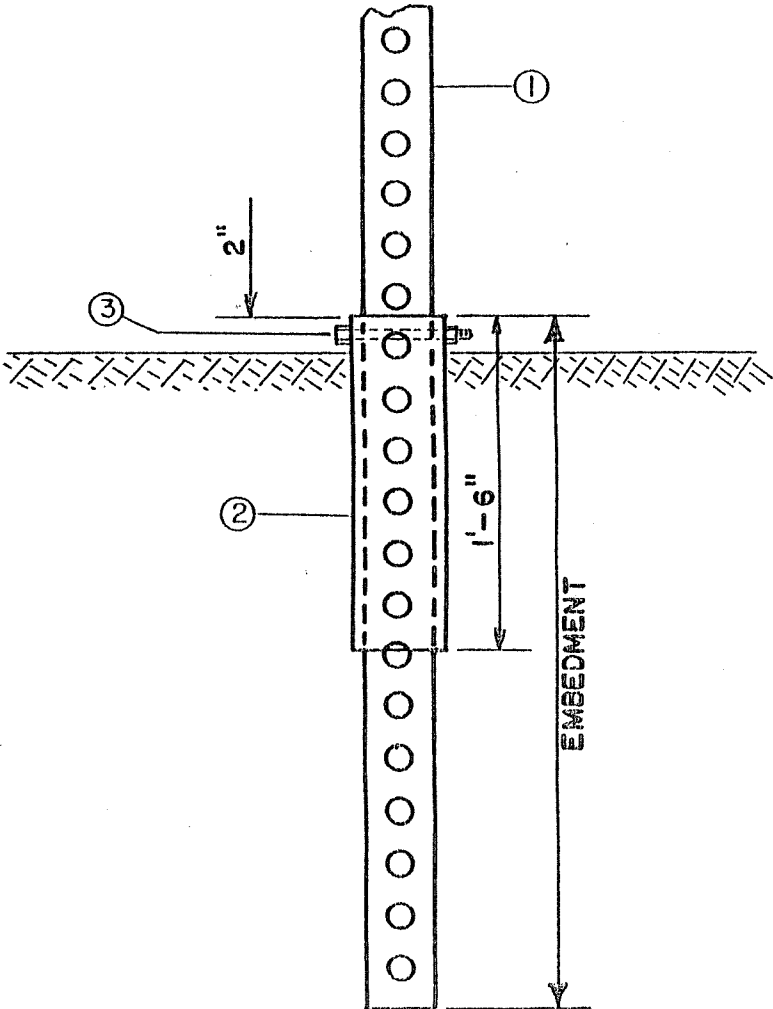

GENERAL NOTES

Soil embedment may be used for all inter-  
sections except state-maintained rights-of-  
way.

EMBEDMENT:

Poorly drained silty soils, 4'-6"  
Well drained gravelly soils, 3'-0"

FAIRBANKS NORTH STAR BOROUGH  
809 PIONEER RD., FBKS AK 99701

TITLE/DWG. NO.

SLEEVE TYPE EMBEDMENT  
(OPTION A)

SS-104

DRAWN BY	DATE	APPROVED BY	DATE	REVISION
				0

# S-05.01

## GENERAL NOTES

1. Unless shown otherwise on the plans, the standard sign offset is 12'. The minimum is 6'.
2. If signs extend over sidewalks, the minimum vertical clearance is 7'-0".
3. Add 6" to mounting height on unpaved roads.
4. If signs extend over bike paths, the minimum vertical clearance is 8'-0".
5. When signs are placed 30' or more from the edge of traveled way, mount them with the bottom of the sign at least 5' above the road surface at the near edge of the road.
6. When multiple hinged sign supports are used, mount hinges at least 7' above the ground.

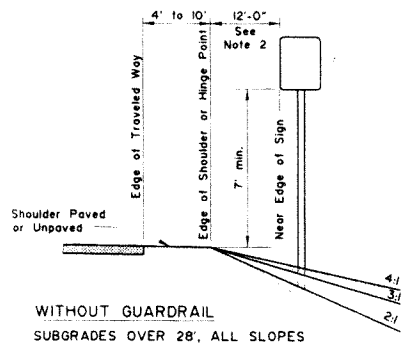

**WITHOUT GUARDRAIL**  
SUBGRADES OVER 28', ALL SLOPES

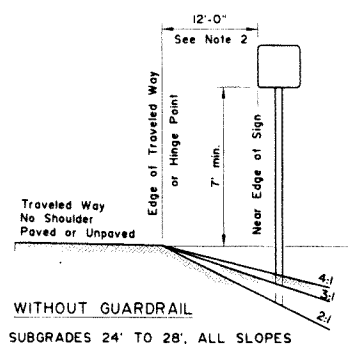

**WITHOUT GUARDRAIL**  
SUBGRADES 24' TO 28', ALL SLOPES

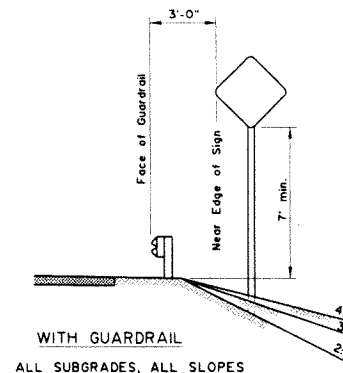

**WITH GUARDRAIL**  
ALL SUBGRADES, ALL SLOPES

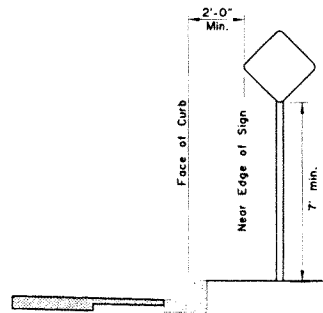

**CURB WITHOUT SIDEWALK**

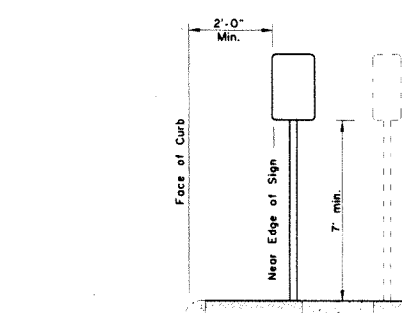

**CURB WITH PARKWAY AND SIDEWALK**  
(If R/W width permits, signs should be placed behind sidewalk.)

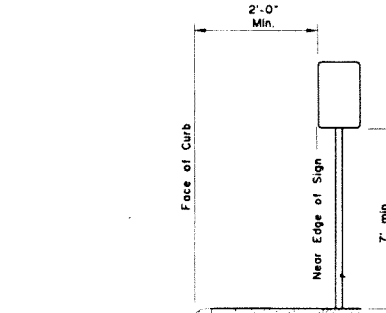

**CURB WITH SIDEWALK WITHOUT PARKWAY**

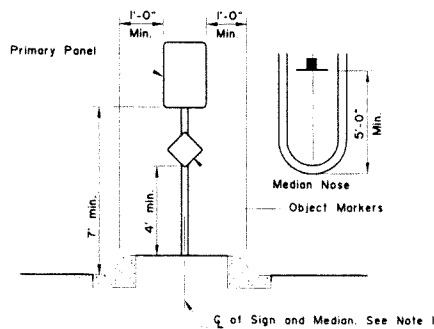

**RAISED MEDIANS**  
Minimum 4' Width for Signing

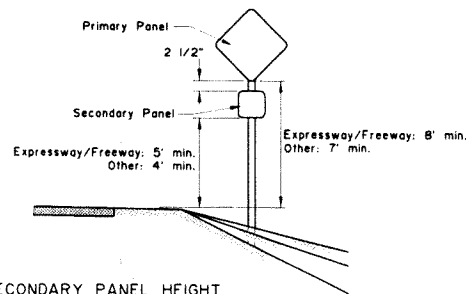

**SECONDARY PANEL HEIGHT**  
ALL TWO PANEL MOUNTING

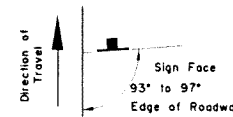

**SIGN POSITIONING**

REVISIONS		
Date	Description	By
4/2/01	Revised Sign Heights	...

Sheet 1 of 1

State of Alaska  
Department of Transportation  
& Public Facilities

**POST MOUNTED SIGN  
OFFSET AND HEIGHT**

APPROVED

19th  
Kurtis J. Smith

Date